

Let's check the adage : "who can do the most, can the least" about the product width / belt width ratio.

## Filling coefficient: Sound impact on the belt and other components of the conveyor!

Everyone wants clean, economical, efficient and robust conveyors with a very high level of safety. The rate of the filling factor of the belt largely participates in achieving this ideal. So why so many conveyors operate with a load factor close to 50%, see less? Would you accept that your trucks run at half load? ... Certainly not !

### THE SITUATION

One often hears that "who can do more, can do less" and this adage, brought back to the conveyor, is found, for example, on the filling coefficient of the bands by limiting it to 50 - 65% of its nominal capacity (**Fig.1**)

Arguments :

- "in case of offset of the strip, there will be no loss of product on the ground",
- "there is free capacity for higher throughput, in the event of a process incident, or for the future".

### Overview

When one observes the products transported by the conveyors, it does not seem, a priori, necessary to specify a minimum width of product on the belt compared to its total width. Conversely, the maximum width of product transported is limited according to ISO 5048, in order to avoid product overflows.

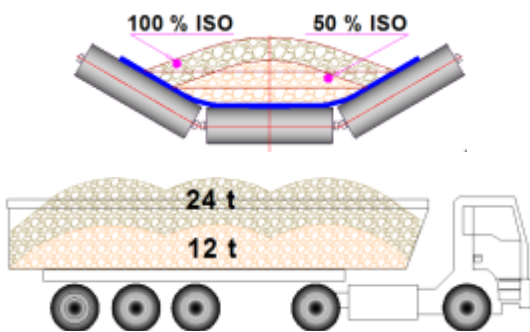
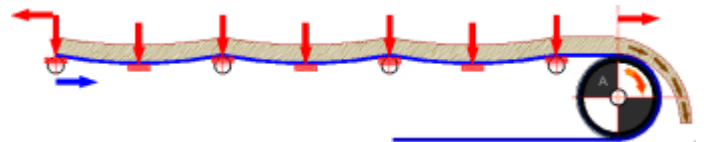

**Figure1:** Filling to 100 % & 50 % ISO 5048 comparison with a dump truck!

### HOW IT WORKS ?

When we observe a belt loaded with product, we can say that it is pulled at its end by the drive pulley and held by the other under the effect of the different resistant forces.

The resistant forces (**Fig.2**) that interest us are those generated by the product handled. Imaginatively we can say that the belt, seen in the sense vertical, is "pinched", like a tight piece in a vice, between the load of product and the supports under the belt.



**Figure 2:** Resistant and tensile forces

To make homogeneous this effect of resistant force on the belt at an acceptable condition, for a given flow rate and for a long life of operation, that is to say of less deformation of belt carcass and of the conveyor components, the ISO 5048 standard specifies a pile width of:  $[(0.9 / B) - 50 \text{ mm}]$ , where B is the belt width (**Fig.1**).

Calculations determine the forces to which the belt is subjected, for a given handling. Then we select a type of belt can respond to calculated efforts. It does not matter what material constitutes the belt carcass; it is its breaking

strength that is deemed authentic, expressed in N / mm width and multiplied by its width

The general case advises that the sum of the forces applied to the belt is at most equal to 10% of its total breaking strength. The idea is not to exceed the elastic limit of belt, either immediately or by fatigue.

### QUESTION

1- Should we put a limit of "minimum width of product" on the belt, so as not to cause problems? In this presentation, the rules relating to the grain size of the products are not taken into account in order to simplify their understanding.

2- What problems are the different components of the conveyor exposed if the width of the product transported on the belt is reduced.

### DESCRIPTION

A "100" width belt, drawn by a drive pulley having an effective web contact width of "100", is considered for a width of the pile of product handled by 50% of belt width. It is considered that the type of belt used to carry out the handling satisfies the rules of the art from the point of view of its total strength, for its total width.

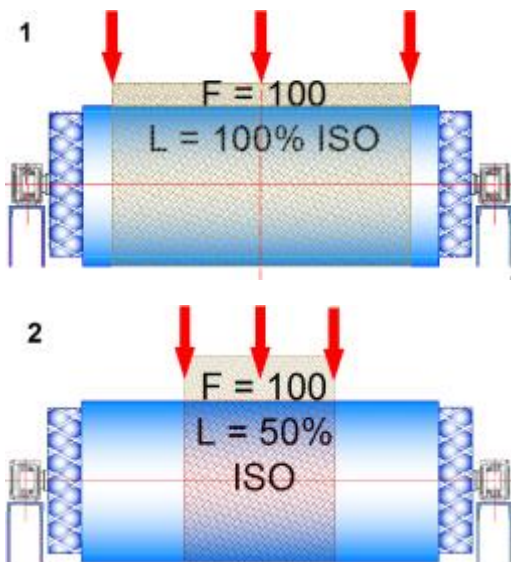

**Figure 3:** Resistant and tensile forces

- 1) Uniformly distributed forces
- 2) Force concentrated on  $\frac{1}{2}$  belt width

### OBSERVATIONS

In our example, we note that there is only a small width of belt that supports the effect of "pinching" (resistant force). Here is the problem!

### FIRST CONSEQUENCE

Because 50 % of belt width is under stress of the product, the warp of the belt carcass, under stress, is stressed by forces greater than the limits allowed by the type of belt installed if, of course, this belt type has not been oversized ... although, calculations show that the resistant forces, reduced to the total width of belt, do not exceed the allowable limit of belt.

### DIRECT CONSEQUENCE

The chain cables of belt carcass, under load handled, support these forces above the allowable limits and therefore undergo a permanent elongation and this phenomenon will only increase over time.

### INDUCED CONSEQUENCES

Because of the deformation of belt carcass, limited to the width under load, quite quickly there is very particular wear of the drive and snub pulleys.

- the surface of drive pulley, corresponding to the width under load, will wear in the shape of a diabolo (concave shape).
- The surface of the snub pulley associated with the drive pulley, and other pulleys of the conveyor, will on the contrary have a convex shape which is constituted by the clogging of the product on the pulley, limited once more to the belt width under load ; this convex deformation will be aggravated by approximately frustoconical wear of the two lateral pulley portions and contiguous to the zone under load.
- The scrapers lose their effectiveness, and increasing their pressure on the belt only worsens the situation.
- The power absorbed by the conveyor can increase considerably, due to a belt deformation, seen in cross-section, similar to a "pocket" which increases the fulling resistance at the passage of the rollers.
  - Here are added the forces needed to "lift" the product handled when passing each roll..

### MISCELLANEOUS CONSEQUENCES

Because of the abovementioned anomalies, it is common to note belt creep on the drive pulley, especially when starting at full load, or to note a drift in speed between these two elements. The

usual reaction of the operators, in this case, is to increase the belt tension and, thus, initiate a new cycle of destruction of the belt and the components of the conveyor.

It appears at this time other damage on the belt, when it is supported on trough supports. Indeed a transition length correctly calculated at the origin, corresponding to a pre-tension completely suitable for the belt, is too short following the increase of the successive pre-tensions (see ISO 5293). This causes belt overtension in the edges which cause their deformation (over-lengthening) with, as a consequence, incomprehensible belt trajectory instabilities and new drive pulley spinning..

### AGGRAVATING FACTORS

- The aggravating factors that cause these situations, taken singly or in combination, are:
- the product width/total width belt ratio that tends to 0 %,
  - whose a lack of chute efficiency for centering the product on the belt
- products with high densities,
- products with a high coefficient of internal friction
- hot products,
- narrow belts of feeder conveyor
  - including hoppers emptying under wagon,
  - with a large column height
- concave curves, with more severe conditions such as induced curves:
  - by the trolleys
  - by the feeder bridges
- idler trough transitions, with raised pulleys (see ISO 5293 # 4.3.2.2)
- large conveyor spacings, strongly upward,
- the belt forming a large deflection between the idlers,
- pulley ferrules too strongly crowned.

### PEMIER EXEMPLE

#### Conveyor of the iron and steel industry:

Center distance 134 m, elevation 32 m, concave curve, slopes from 0 ° to 20 °, trough idlers at 30 °, 3 rollers, diameter 133 mm, spacing 700 mm, installed power 160 kW, belt speed 1.27 m / s, frequent stop at full load and restart.

Belt type **1250 N/mm**, width **1600 mm**.

Product: ore, density 2.2, fine grain size (0 to 10), slope angle 30 °, temperature 60 ° C, mass of product per meter belt: 490 kg, product width 800 mm, or 50% of belt. For the same total resistance, it would have been preferable to have a width of **1200 mm** belt type **1600 N/mm**, or a belt width **1000 mm** type **2000 N/mm**. The belt corresponding

to the first suggestion can be mounted on the current conveyor without modification, contrary to the second suggestion.

### SECOND EXAMPLE

#### Conveyor type mines:

Center distance 422 m, elevation 83 m, slope 12 °, idlers of type garland, deep trough, spacing 2400 mm, installed power 640 kW, belt speed 4,17 m / s, Product: coal, density 1,2, fine particle size to 500 mm, the ratio product width / total width band is between 30% and 50%.

The first deteriorated elements are the pulleys and the belt splices.

### THIRD EXAMPLE

#### Conveyor Handling Bags:

Center distance 30 m, 5 m elevation, donkey back profile, the drive pulley ferrule shape is a squirrel-cage, strongly crowned, the belt support is one black sheet metal sliding sole for each straight section and with 1 roller at each convex curve. Belt width 650 mm. Product: paper bags 400 \* 700 mm, width resting on the belt 250 mm (the bags are bulging), unit weight 25 kg, flow 250-400 bags / h, width of the belt 650 mm

Here, the aggravating factor, because of the accelerated degradation of the band, is in the shape and type of drive pulley and the force concentrated on the belt by the bag surface contacts which is small..

### CONCLUSION

It is in the interest of conveyor operators to have conveyors with a "product width / total width" ratio between 85% and 100% of ISO 5048.

Therefore, it is important that the load factors of belts, much lower than 85% of the ISO, are not the argument to compensate for a lack of flow mastery upstream of the said conveyor or a lack of mastery of belt trajectory.

**Marc des Rieux, Expert**

✉ [marc.desrieux@c3-expert.com](mailto:marc.desrieux@c3-expert.com)

🌐 [www.c3-expert.com](http://www.c3-expert.com)

Cet article a été publié / This article was published in :  
Infovrac Février 1995